

Project Name:	Approval:
Location:	Date:
Engineer:	Construction:
Submitted to:	Unit #:
Submitted by:	Drawing #:
Reference:	

SPECIFICATIONS:

Model	DCM601B71	DCM601A72
Description	intelligent Touch Manager (iTM)	iTM Plus Adaptor
Maximum Indoor Unit Groups	64	64
Max Indoor Units	128	128
Max Outdoor Units	10	10
Max BACnet Servers	50	-
System Total	512 Indoor Unit Groups (1024 Indoor Units)	
Power Supply	24 VAC, 60 Hz	24 VAC, 60 Hz
Power Consumption	23 Watts	23 Watts
Operating Temp Range	32-104°F	14 - 122°F
Operating Humidity Range	85% or less (w/o condensation)	85% or less (w/o condensation)
Dimensions (W x H x D)	11.42 x 9.57 x 1.97 in.	6.30 x 5.87 x 2.41 in.
Weight (Mass)	5.3 lbs. (2.4 kg)	1.1 lbs. (0.5 kg)
Certifications	FCC Part 15 Class B	
DIII-NET Systems	1	1
RJ-45 (Ethernet) 100Base-TX or 10Base-T	2	N/A
USB Port-USB2.0 (2GB to 32GB)	1	N/A
RS485 (19 - 22 AWG)	1	1
Digital Input forced shutdown of all indoor unit systems	1	N/A
Digital Input and/or Pulse Input Terminals	3 x 10 mA @ 16 VDC/ 3 x 1 pulse at 1 or 10 kWh at 100 ms interval	4 x 10 mA @ 16 VDC/ 4 x 1 pulse at 1 or 10 kWh at 100 ms interval

PRODUCT IMAGE:



iTM



**iTM Plus Adaptor
(Optional)**

OPTIONS:

- Software Options:
 - Power Proportional Distribution (PPD) Option (DCM002A71) ⁽¹⁾
 - Web (HTTP) Interface Software (DCM007A51)
 - BACnet Client Option Software (DCM009A51)
 - BACnet/IP Server Gateway Option (DCM014A51) ⁽²⁾⁽³⁾
- Hardware Options:
 - iTM Plus Adapter (DCM601A72) for expanding indoor unit groups up to 512 groups (1024 indoor units)
 - WAGO I/O basic kit (60359653) and I/O modules for controlling/ monitoring of external equipment via Di, Do, Ai, Ao and Pi
- Spare Parts:
 - iTM Sliding Door (Part# B72A930)
 - SD Card (Part# 2336767)



Submittal Data Sheet

DCM601B71 – intelligent Touch Manager

Project Name:	Approval:
Location:	Date:
Engineer:	Construction:
Submitted to:	Unit #:
Submitted by:	Drawing #:
Reference:	

Notes:

- (1) The Power Proportional Distribution (PPD) option supplies the user with a reasonably calculated apportionment of the total power consumption by the Daikin air-conditioning system to individual units on the system. Because input to the PPD includes measured pulses in the refrigerant system and because the air-conditioning system includes number of variables, to include operating temperatures and pressures, piping lengths, heat exchange rates and others, no meter-type apportionment of individual user’s consumption can be made. However, the PPD feature provides an apportionment methodology that uses highly advanced technology as applied to the many variables in the air-conditioning system.
- (2) The BACnet Server Gateway option cannot use together with the BACnet Client software option.
- (3) BACnet/IP Server Gateway option is not compatible with the VAM unit or the Low Temp Hydrobox.

MODEL COMPATIBILITY:

The following indoor units are compatible with the iTM:

System	Model
VRV and VRV Life™	FXAQ, FXDQ, FXEQ, FXFQ, FXHQ, FXLQ, FXMQ, FXMQ_MF, FXNQ, FXSQ, FXTQ, FXUQ, FXZQ, CXTQ, VAM*, Low Temperature Hydrobox (HXY48TAVJ)*
SkyAir	FAQ, FBQ, FCQ, FHQ, FTQ
Single Zone/Multi Zone/SkyAir	<ul style="list-style-type: none"> FDMQ, FFQ_Q FFQ_LVJU with the use of the Interface Adaptor DTA112BA51 FTXS, CTXS, CTXG, FTXG, FDXS, CDXS, FVXS with the use of the DIII-Net Adapter KRP928BB2S FTK_N, FTX_N, FTX_U, FTXN, and FTKN with the use of the DIII-Net Adapter KRP928BB2S and an Interface adaptor KRP067A41E/KRP980B1/KRP980B2E

**iTM BACnet Server Gateway Option is not compatible with VAM unit and LT Hydrobox*

The outdoor operational data is available for the following outdoor unit models:

VRV Family	Model
VRV III S	RXYMQ_PVJU
VRV IV S	RXTQ_TAVJU
VRV LIFE	RXSQ_TAVJU
VRV III	RXYQ_PBTJ, RXYQ_PBYD, REYQ_PATJ, REYQ_PBTJ, REYQ_PBYD, REYQ_PCTJ, REYQ_PCYD, RWEYQ_PTJU and RWEYQ_PYDN
VRV AURORA	RXLQ_TATJU, RXLQ_TAYDU, RXLQ_TAYCU, RELQ_TATJU, RELQ_TAYDU and RELQ_TAYCU
VRV IV X	REYQ_XATJU, REYQ_XAYDU, REYQ_XAYCU, RXYQ_XATJA, RXYQ_XAYDA, REYQ_XATJA, REYQ_XAYDA, REYQ_XAYCA
VRV T	RWEQ_TATJU, RWEQ_TAYDU, RWEQ_TAYCU
VRV IV	RXYQ_TTJU, RXYQ_TATJU, RXYQ_TAYDU, REYQ_TATJU, REYQ_TAYDU, RXYQ_TAYCU, RXYQ_TYDN, REYQ_TAYCU, REYQ_TTJU, REYQ_TYDN, RWEYQ_PCTJ and RWEYQ_PCYD
VRV Emerion	REYQ_AATJA, REYQ_AAYDA, RXYQ_AATJA, RXYQ_AAYDA



Submittal Data Sheet

DCM601B71 – intelligent Touch Manager

Project Name:		Approval:	
Location:		Date:	
Engineer:		Construction:	
Submitted to:		Unit #:	
Submitted by:		Drawing #:	
Reference:			

FEATURES:

1. **Management size** - up to 512 indoor unit groups (1024 indoor units).
 - a. The iTM can manage one (1) DIII-Net system which can have up to 64 indoor unit groups (128 indoor units).
 - b. The iTM can manage up to eight (8) DIII-Net systems with the addition of the iTM Plus Adapter which can manage one (1) DIII-Net system each. This means up to seven (7) iTM adapters can be daisy chained to the iTM.
2. **Control / Monitoring**
 - a. Independent Cool and Heat setpoints
 - i. Setpoint tracking for full range of setpoint differentials
 - b. Independent Cool and Heat Setback setpoints (unoccupied)
 - i. Adjustable timed override
 - c. Room temperature displayed in 0.1°F
 - d. Scheduling: 7, 5+2, 5+1+1, 1 (Everyday) weekly patterns
 - i. Optimum Start
 - ii. Schedule the capacity demand limit of the outdoor unit's compressor by 0%, 40%, 70% or 100%
 - iii. Schedule the outdoor unit low noise operation
 - e. Auto-changeover: Fixed, Individual, Average, and Vote
 - i. Weighted demand (0-3) configurable for Average and Vote methods
 - ii. Adjustable (1-4°F) Primary and Secondary changeover bands
3. **Web Accessibility**
 - a. Web and Alert Email function standard with iTM
 - b. All iTM configuration/setup can be done through Web Option or touch screen
4. **Visual Navigation Screen**
 - a. Floor plan layout view is available
 - b. Graphical User Interface (GUI) for BACnet IP Client management points
5. **Easy installation**
 - a. Wall mount and flush mount installation.
 - b. Automatic indoor unit registration and indoor unit model detection.
6. **Easy Engineering**
 - a. iTM can be configured off site via Pre-setting Tool.
 - b. All data can be uploaded and downloaded by USB flash drive.
7. **Building facilities management**
 - a. The iTM is equipped with 3 digital/pulse inputs and the iTM Plus Adapter comes equipped with 4 digital/pulse inputs.
 - b. Building ancillary equipment can be connected by using the WAGO I/O system (optional).
 - i. I/O configuration for Digital Input, Digital Output, Analog Input, Analog Output and Pulse Input.
 - c. BACnet IP Client management points with BACnet Client option (optional).
 - i. AI, AO, AV, BI, BO, BV, MI, MO and MV
8. **Power Proportional Distribution (PPD) (Optional)**
 - a. Provide function to distribute the energy consumption of the Outdoor units to the selected indoor unit group address, based on indoor unit operation duration, electronic expansion valve opening ration, indoor size etc.
 - b. Up to 512 indoor unit group address
 - c. PPD data can be downloaded in CSV format to a PC or USB flash drive



Submittal Data Sheet

DCM601B71 – intelligent Touch Manager

Project Name:	Approval:
Location:	Date:
Engineer:	Construction:
Submitted to:	Unit #:
Submitted by:	Drawing #:
Reference:	

9. Web (HTTP) Interface Software (Optional)

- a. Provide function to monitor and control up to 512 indoor unit group addresses by a BMS via HTTP protocol.
- b. The following data points are available: Fan Speed - Louver Direction - Ventilation Mode - Ventilation Amount - Normal/Error monitor - On/Off - Operation Mode – Setpoint - Room Temp

10. BACnet Client (Optional)

- a. Monitor and control equipment and sensors connected to a BACnet server via BACnet IP.
 - i. Up to 50 BACnet IP servers can be connected

11. BACnet Server Gateway (Optional)

- a. Provide function to monitor outdoor units and control indoor units by BMS via BACnet IP.
 - i. Up to 128 BACnet Device IDs (including indoor unit groups and outdoor units)
 - ii. Up to 4000 BACnet objects
 - iii. Virtual BACnet router function embedded
 - i. Individual and configurable Device ID for each indoor unit group and/or outdoor unit system.

12. History

- a. All errors, operations, automatic controls and status changes are stored in history (up to 500,000 items).

13. D-Net compatible (Service option)

- a. Remote monitoring of VRV equipment status and reporting

14. Operation Data

- a. Operation data are stored in the iTM every minute for the last 5 days.
 - i. Indoor and outdoor unit operation data.
 - ii. BACnet Client management data points (AI, AO, AV, BI, BO, BV, MI, MO and MV).
 - iii. WAGO IO system data points (External DI, DIO, PI, AI and AO).
- b. The operation data can be exported through the iTM web browser or a USB drive based on a specified period. (See iTM BACnet Server points list below for IDU/ODU operational data list)

15. Demand Limiting

- a. Interlock the digital input signals to provide the following automatic demand control functions
 - i. Indoor unit set-point shift control
 - ii. Indoor unit forced thermo-off
 - iii. Indoor unit on/off control
 - iv. Outdoor unit’s capacity demand limit control

WIRING SPECIFICATION:

Specifications of Communication Cabling	
DIII-Net	
Type	2-conductor, stranded, non-shielded copper cable / PVC of vinyl jacket
Size	AWG 18-2
Total Length	Maximum wiring distance between units 3,280 ft. Total wire length 6,560 ft.
iTM Plus Adapter	
Type	2-conductor, stranded, non-shielded copper cable / PVC of vinyl jacket
Size	AWG 18-2
RS485 Length	Maximum distance between iTM and furthest iTM Plus Adapter 150 ft.
Total Length	Maximum wiring distance between units 3,280 ft. Total wire length 6,560 ft.

DAIKIN COMFORT TECHNOLOGIES NORTH AMERICA, INC.

19001 Kermier Road • Waller, TX 77484

www.daikinac.com www.daikincity.com

Rev.1022



Submittal Data Sheet

DCM601B71 – intelligent Touch Manager

Project Name:	Approval:
Location:	Date:
Engineer:	Construction:
Submitted to:	Unit #:
Submitted by:	Drawing #:
Reference:	

WAGO	
Type	2-conductor, stranded, non-shielded copper cable / PVC of vinyl jacket (CPEV or FCPEV)
Size	2 Wire AWG 24 - 18 stranded
Total Length	Maximum wiring distance between iTM and Bus Coupler 1640 ft.

BACNET CLIENT OPTION MANAGEMENT POINTS:

- The following BACnet object types can be monitored and controlled by iTM through BACnet Client Option (DCM009A51) via the BACnet/IP protocol:

Object Type #	Object Name	Description
0	Analog Input	Analog input value such as a temperature and measurement value.
1	Analog Output	Analog output value such as a setting value (For example, can be used as the analog input value of a setting value).
2	Analog Value	Analog input value such as a temperature and measurement value or analog output value such as a setting value.
3	Binary Input	Digital input value such as an On/Off status and error status.
4	Binary Output	Digital output value such as an On/Off operation (For example, can be used as the digital input value of an On/Off operation).
5	Binary Value	Digital input value such as an On/Off status and error status or digital output value such as an On/Off operation.
13	Multi-state Input	Digital input value such as an operation mode
14	Multi-state Output	Digital output value such as an operation mode (For example, can be used as the digital input value of an operation mode).
19	Multi-state Value	Digital input value such as an operation mode or digital output value such as an operation mode.

BACNET/IP SERVER GATEWAY OPTION POINTS LIST:

- System configuration points linked to iTM control logic (one set of points per iTM):**

Point Name	Point Description
Enable ITM Schedule Operation	Enable or Disable iTM Schedule operation
Enable ITM Auto Changeover Operation	Enable or disable iTM Auto changeover logic.
Timed Override Minutes	Set override time in minutes
System Forced Off	The Forced System Stop command will force the indoor unit to stop running. Remote controllers will be locked out from restarting indoor units during the forced system stop event.

- Indoor unit monitoring points (one set of points per indoor unit group):**

Point Name	Point Description
Unit On_Off Status	Monitors if the indoor unit fan is On or Off



Submittal Data Sheet

DCM601B71 – intelligent Touch Manager

Project Name: _____	Approval: _____
Location: _____	Date: _____
Engineer: _____	Construction: _____
Submitted to: _____	Unit #: _____
Submitted by: _____	Drawing #: _____
Reference: _____	

Alarm Status	Monitors whether or not the indoor unit is operating normally, and issues an alarm if the indoor unit has a malfunction. Error Code is shown in the description.
Room Temperature	Monitors and displays the room temperature.
Unit On Details	Indoor unit details operation Off - Normal (ON) - Override - Setback
Filter Sign Status	Monitors filter run time and provides service alert.
Indoor Fan Status	Monitors if the indoor unit fan is On or Off
Communication Status	Monitor if the communication is Normal or in Alarm
Thermo-on Status	Monitors whether or not the indoor unit is actively cooling or heating.
Compressor Status	Monitors if the compressor of the outdoor unit is On/Off/Defrost
Aux Heater Status	Monitors if the external heater controlled by the indoor unit is operating.
Changeover Option	Monitor if iTM changeover logic is Active.
Return Air Temperature	Monitors and displays the return air temperature.
Discharge Air Temperature	Monitors and displays the discharge air temperature of the FXMQ_PB indoor unit only.
Liquid Pipe Temperature	Monitors and displays the liquid pipe temperature.
Gas Pipe Temperature	Monitors and displays the gas pipe temperature.
EV Position	Monitors and displays the expansion valve position.
Freeze Protection	Monitors if the freeze protection is active (For FXEQ_P, FXFQ_T, FXTQ_TA, FXUQ_P, FXZQ_TA, FXSQ_TA, CXTQ_TA indoor unit only).

• **Indoor unit monitoring and control points (one set of points per indoor unit group):**

Point Name	Point Description
Occupancy Mode	Set the occupancy of the indoor unit Occupied , Unoccupied or Standby
Operation mode	Set Cool - Heat -Fan -Dry operation mode. for the indoor unit and monitors the latest mode
Occ Cooling Setpoint	Sets the occupied cooling setpoint of the indoor unit and monitors the latest setpoint value.
Occ Heating Setpoint	Sets the occupied heating setpoint of the indoor unit and monitors the latest setpoint value.
Unocc Cooling Setpoint	Sets the unoccupied cooling setpoint of the indoor unit and monitors the latest setpoint value.
Unocc Heating Setpoint	Sets the occupied heating setpoint of the indoor unit and monitors the latest setpoint value.
Max Cooling Setpoint	Sets the maximum cooling setpoint of the indoor unit and monitors the latest setpoint value.
Min Cooling Setpoint	Sets the minimum cooling setpoint of the indoor unit and monitors the latest setpoint value.
Max Heating Setpoint	Sets the maximum Heating setpoint of the indoor unit and monitors the latest setpoint value.
Min Heating Setpoint	Sets the minimum heating setpoint of the indoor unit and monitors the latest setpoint value.
Min Setpoint Differential (Cooling & Heating)	Set the minimum differential value between cooling and heating setpoint and monitor the latest differential value.
Cooling & Heating Setpoint Tracking Mode	Enable or disable iTM setpoint tracking mode.
Fan speed	Sets the indoor unit fan speed and monitors the latest setting



Submittal Data Sheet

DCM601B71 – intelligent Touch Manager

Project Name:	Approval:
Location:	Date:
Engineer:	Construction:
Submitted to:	Unit #:
Submitted by:	Drawing #:
Reference:	

Timed Override Operation	Enable or disable iTM override timer
Remote Controller Prohibit (On_Off)	Permits or prohibits the remote controller to control the indoor unit's On/Off.
Remote Controller Prohibit (Operation Mode)	Permits or prohibits the remote controller to control the indoor unit's Operation mode.
Remote Controller Prohibit (Setpoint)	Permits or prohibits the remote controller to control the indoor unit's Setpoint.
Filter Sign Reset	Clears the filter sign status.
Forced Thermo-off	Force the indoor unit to stop actively cooling or heating.

• **Outdoor unit monitoring points*:**

Point Name	Point Description
Communication Status	Monitors and displays the communication status <i>(General)</i>
Operation Mode	Monitors and displays the operation mode (Cool, Heat, Fan or Heat &Cool) <i>(General)</i>
Outdoor Unit Alarm Status	Monitors whether or not the outdoor unit is operating normally. <i>(General)</i>
Defrost Mode	Monitors if the defrost mode is active. <i>(General)</i>
Oil Return Mode	Monitors whether or not the outdoor unit is in oil return operation. <i>(General)</i>
Electric Power	Monitors and displays the electric power (calculated). <i>(General)</i>
Electric Current	Monitors and displays the electric current (calculated). <i>(General)</i>
System Capacity Code	Monitors and displays the system capacity code. <i>(General)</i>
Outdoor Air Temperature	Monitors and displays the outdoor air temperature. <i>(General)</i>
M_Condensing Pressure	Monitors and displays the condensing pressure <i>(Master Module)</i>
M_Evaporating Pressure	Monitors and displays the evaporating pressure <i>(Master Module)</i>
M_Condensing Temperature	Monitors and displays the condensing temperature <i>(Master Module)</i>
M_Evaporating Temperature	Monitors and displays the evaporating temperature <i>(Master Module)</i>
M_Inverter Compressor 1 Speed	Monitors and displays the speed of the inverter compressor1 <i>(Master Module)</i>
M_Inverter Compressor 2 Speed	Monitors and displays the speed of the inverter compressor2 <i>(Master Module)</i>
M_Fan Step	Monitors and displays the fan step <i>(Master Module)</i>
M_EV Position 1	Monitors and displays the position of the expansion valve1 <i>(Master Module)</i>
M_EV position 2	Monitors and displays the position of the expansion valve2 <i>(Master Module)</i>
M_Hot Gas Temperature (Compressor 1)	Monitors and displays the hot gas temperature of the compressor1 <i>(Master Module)</i>
M_Hot Gas Temperature (Compressor 2)	Monitors and displays the hot gas temperature of the compressor2 <i>(Master Module)</i>
M_Liquid Pipe Temperature	Monitors and displays the liquid pipe temperature <i>(Master Module)</i>
M_Liquid Pipe Temperature (HX Upper)	Monitors and displays the liquid pipe temperature for the upper HX <i>(Master Module)</i>
M_Liquid Pipe Temperature (HX Lower)	Monitors and displays the liquid pipe temperature for the lower HX <i>(Master Module)</i>
M_Liquid Pipe Temperature (De-Icer)	Monitors and displays the liquid pipe temperature for the de-icer <i>(Master Module)</i>



Submittal Data Sheet

DCM601B71 – intelligent Touch Manager

Project Name:	
Location:	Approval:
Engineer:	Date:
Submitted to:	Construction:
Submitted by:	Unit #:
Reference:	Drawing #:

M_Gas Pipe Temperature (HX Upper)	Monitors and displays the gas pipe temperature for the upper HX <i>(Master Module)</i>
M_Gas Pipe Temperature (HX Lower)	Monitors and displays the gas pipe temperature for the lower HX <i>(Master Module)</i>
M_Suction Temperature	Monitors and displays the suction temperature <i>(Master Module)</i>
M_Compressor Suction Temperature	Monitors and displays the compressor's suction temperature <i>(Master Module)</i>
M_Subcool Inlet Temperature	Monitors and displays the subcool inlet temperature <i>(Master Module)</i>
M_Subcool Outlet temperature	Monitors and displays the subcool outlet temperature <i>(Master Module)</i>
M_Subcool EV Position	Monitors and displays the subcool expansion valve position <i>(Master Module)</i>
S1_Condensing Pressure	Monitors and displays the condensing pressure <i>(Sub Module1)</i>
S1_Evaporating Pressure	Monitors and displays the evaporating pressure <i>(Sub Module1)</i>
S1_Condensing Temperature	Monitors and displays the condensing temperature <i>(Sub Module1)</i>
S1_Evaporating Temperature	Monitors and displays the evaporating temperature <i>(Sub Module1)</i>
S1_Inverter Compressor 1 Speed	Monitors and displays the speed of the inverter compressor1 <i>(Sub Module1)</i>
S1_Inverter Compressor 2 Speed	Monitors and displays the speed of the inverter compressor2 <i>(Sub Module1)</i>
S1_Fan Step	Monitors and displays the fan step <i>(Sub Module1)</i>
S1_EV Position 1	Monitors and displays the position of the expansion valve1 <i>(Sub Module1)</i>
S1_EV position 2	Monitors and displays the position of the expansion valve2 <i>(Sub Module1)</i>
S1_Hot Gas Temperature (Compressor 1)	Monitors and displays the hot gas temperature of the compressor1 <i>(Sub Module1)</i>
S1_Hot Gas Temperature (Compressor 2)	Monitors and displays the hot gas temperature of the compressor2 <i>(Sub Module1)</i>
S1_Liquid Pipe Temperature	Monitors and displays the liquid pipe temperature <i>(Sub Module1)</i>
S1_Liquid Pipe Temperature (HX Upper)	Monitors and displays the liquid pipe temperature for the upper HX <i>(Sub Module1)</i>
S1_Liquid Pipe Temperature (HX Lower)	Monitors and displays the liquid pipe temperature for the lower HX <i>(Sub Module1)</i>
S1_Liquid Pipe Temperature (De-Icer)	Monitors and displays the liquid pipe temperature for the de-icer <i>(Sub Module1)</i>
S1_Gas Pipe Temperature (HX Upper)	Monitors and displays the gas pipe temperature for the upper HX <i>(Sub Module1)</i>
S1_Gas Pipe Temperature (HX Lower)	Monitors and displays the gas pipe temperature for the lower HX <i>(Sub Module1)</i>
S1_Suction Temperature	Monitors and displays the suction temperature <i>(Sub Module1)</i>
S1_Compressor Suction Temperature	Monitors and displays the compressor's suction temperature <i>(Sub Module1)</i>
S1_Subcool Inlet Temperature	Monitors and displays the subcool inlet temperature <i>(Sub Module1)</i>
S1_Subcool Outlet temperature	Monitors and displays the subcool outlet temperature <i>(Sub Module1)</i>
S1_Subcool EV Position	Monitors and displays the subcool expansion valve position <i>(Sub Module1)</i>
S2_Condensing Pressure	Monitors and displays the condensing pressure <i>(Sub Module2)</i>
S2_Evaporating Pressure	Monitors and displays the evaporating pressure <i>(Sub Module2)</i>
S2_Condensing Temperature	Monitors and displays the condensing temperature <i>(Sub Module2)</i>
S2_Evaporating Temperature	Monitors and displays the evaporating temperature <i>(Sub Module2)</i>
S2_Inverter Compressor 1 Speed	Monitors and displays the speed of the inverter compressor1 <i>(Sub Module2)</i>

DAIKIN COMFORT TECHNOLOGIES NORTH AMERICA, INC.
 19001 Kermier Road • Waller, TX 77484
www.daikinac.com www.daikincity.com

Rev.1022

(Daikin's products are subject to continuous improvements. Daikin reserves the right to modify product design, specifications and information in this data sheet without notice and without incurring any obligations)



Submittal Data Sheet

DCM601B71 – intelligent Touch Manager

Project Name:	Approval:
Location:	Date:
Engineer:	Construction:
Submitted to:	Unit #:
Submitted by:	Drawing #:
Reference:	

S2_Inverter Compressor 2 Speed	Monitors and displays the speed of the inverter compressor2 <i>(Sub Module2)</i>
S2_Fan Step	Monitors and displays the fan step <i>(Sub Module2)</i>
S2_EV Position 1	Monitors and displays the position of the expansion valve1 <i>(Sub Module2)</i>
S2_EV position 2	Monitors and displays the position of the expansion valve2 <i>(Sub Module2)</i>
S2_Hot Gas Temperature (Compressor 1)	Monitors and displays the hot gas temperature of the compressor1 <i>(Sub Module2)</i>
S2_Hot Gas Temperature (Compressor 2)	Monitors and displays the hot gas temperature of the compressor2 <i>(Sub Module2)</i>
S2_Liquid Pipe Temperature	Monitors and displays the liquid pipe temperature <i>(Sub Module2)</i>
S2_Liquid Pipe Temperature (HX Upper)	Monitors and displays the liquid pipe temperature for the upper HX <i>(Sub Module2)</i>
S2_Liquid Pipe Temperature (HX Lower)	Monitors and displays the liquid pipe temperature for the lower HX <i>(Sub Module2)</i>
S2_Liquid Pipe Temperature (De-Icer)	Monitors and displays the liquid pipe temperature for the de-icer <i>(Sub Module2)</i>
S2_Gas Pipe Temperature (HX Upper)	Monitors and displays the gas pipe temperature for the upper HX <i>(Sub Module2)</i>
S2_Gas Pipe Temperature (HX Lower)	Monitors and displays the gas pipe temperature for the lower HX <i>(Sub Module2)</i>
S2_Suction Temperature	Monitors and displays the suction temperature <i>(Sub Module2)</i>
S2_Compressor Suction Temperature	Monitors and displays the compressor's suction temperature <i>(Sub Module2)</i>
S2_Subcool Inlet Temperature	Monitors and displays the subcool inlet temperature <i>(Sub Module2)</i>
S2_Subcool Outlet temperature	Monitors and displays the subcool outlet temperature <i>(Sub Module2)</i>
S2_Subcool EV Position	Monitors and displays the subcool expansion valve position <i>(Sub Module2)</i>

DIMENSIONS:

iTM:

Project Name: _____
 Location: _____
 Engineer: _____
 Submitted to: _____
 Submitted by: _____
 Reference: _____

Approval: _____
 Date: _____
 Construction: _____
 Unit #: _____
 Drawing #: _____

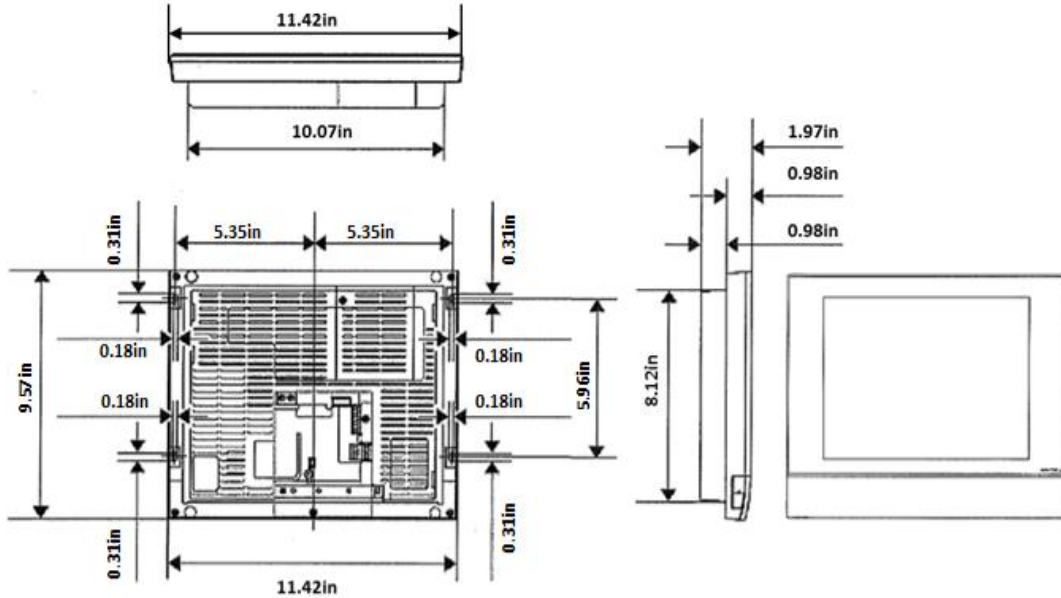

iTM Plus Adaptor:

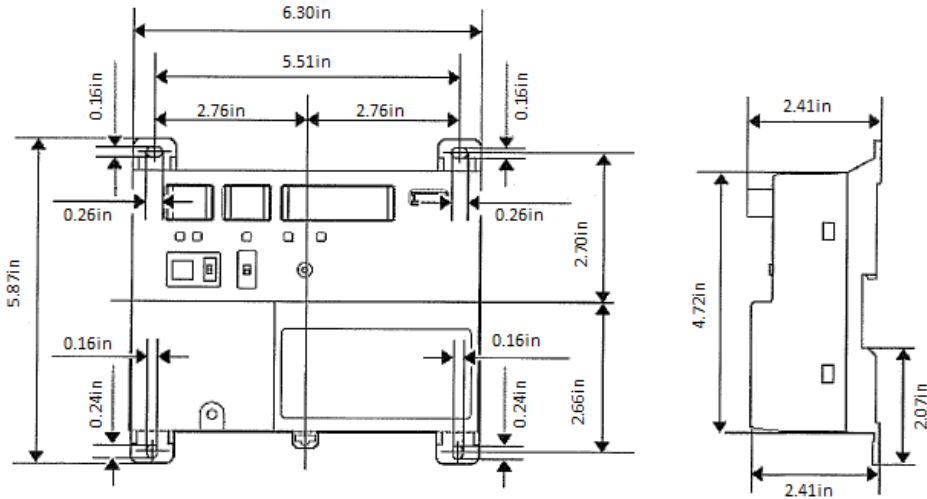

DOCUMENTATION:

Documentation available on www.daikincity.com and/or www.daikinac.com:

DAIKIN COMFORT TECHNOLOGIES NORTH AMERICA, INC.
 19001 Kermier Road • Waller, TX 77484
www.daikinac.com www.daikincity.com

Rev.1022



Submittal Data Sheet

DCM601B71 – intelligent Touch Manager

Project Name:		Approval:	
Location:		Date:	
Engineer:		Construction:	
Submitted to:		Unit #:	
Submitted by:		Drawing #:	
Reference:			

- Submittal
- Sales Brochure
- Guide Specs
- Installation Manual
- Operation Manual
- iTM D3 Operation Data Analysis Tool
- iTM BACnet Server Gateway
 - Design Guide
 - Sales Flyer
 - Quick User Guide
- iTM BACnet Client
 - Sales Flyer
 - iTM BACnet Client macro tools
- WAGO I/O Basic Kit and Modules
 - Submittal
 - Installation Manual
 - Sales Flyer